

SIEMENS

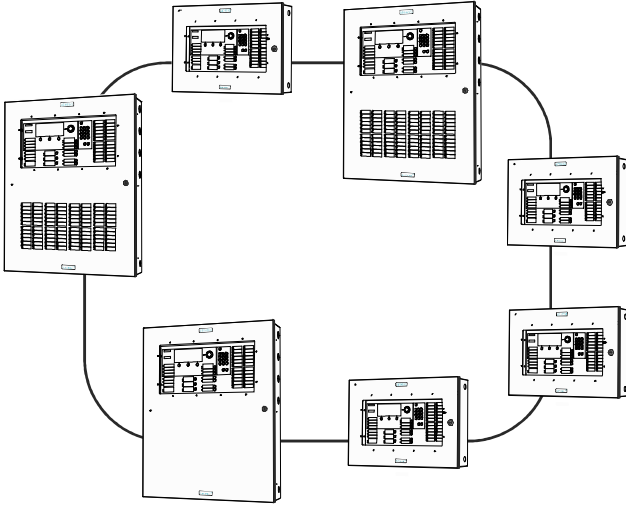

FC922 / FC924 / FT924

FV922 / FV924 / VR2005

Fire Alarm Control Panel

Installation Instructions

MP-UL 3.1

Legal Notice

Technical specifications and availability subject to change without notice.

© 2020 Copyright by Siemens Industry, Inc.

Transmittal, reproduction, dissemination and/or editing of this document as well as utilization of its contents and communication thereof to others without express authorization are prohibited. Offenders will be held liable for payment of damages. All rights created by patent grant or registration of a utility model or design patent are reserved.

Edition: 2020-10-21

Document ID: A6V10356958_en--_n



Cyber security disclaimer

Siemens provides a portfolio of products, solutions, systems and services that includes security functions that support the secure operation of plants, systems, machines and networks. In the field of Building Technologies, this includes building automation and control, fire safety, security management as well as physical security systems.

In order to protect plants, systems, machines and networks against cyber threats, it is necessary to implement – and continuously maintain – a holistic, state-of-the-art security concept. Siemens' portfolio only forms one element of such a concept. You are responsible for preventing unauthorized access to your plants, systems, machines and networks which should only be connected to an enterprise network or the internet if and to the extent such a connection is necessary and only when appropriate security measures (e.g. firewalls and/or network segmentation) are in place. Additionally, Siemens' guidance on appropriate security measures should be taken into account. For additional information, please contact your Siemens sales representative or visit <https://www.siemens.com/global/en/home/company/topicareas/future-of-manufacturing/industrial-security.html>.

Siemens' portfolio undergoes continuous development to make it more secure. Siemens strongly recommends that updates are applied as soon as they are available and that the latest versions are used. Use of versions that are no longer supported, and failure to apply the latest updates may increase your exposure to cyber threats. Siemens strongly recommends to comply with security advisories on the latest security threats, patches and other related measures, published, among others, under <https://www.siemens.com/cert/en/cert-security-advisories.htm>.

Table 1: Limitations and Restrictions per UL864, sec 90.23

Notice to Users, Installers, Authorities Having Jurisdiction (AHJ) and Other Involved Parties			
This product incorporates field-programmable software. In order for the product to comply with the requirements in the Standard for Control Units and Accessories for Fire Alarm Systems, UL864, certain programming features or options must be limited to specific value or not used at all as indicated below.			
Program Feature or Options	Permitted in UL864? (Y/N)	Possible Setting	Setting Permitted in UL864
Ability to change the volume for the sounder on the FACP	Y	Adjustment of the sounder volume on the Operating Unit Menu ranges from Loud to Max to Low to Min to Bypassed	Setting of the <u>Sounder Volume</u> must be greater than " Bypassed " setting. Default must be set to Max
Global Access Point (GAP) using Ethernet connection *	Y	Ability to connect the FACP network using the Ethernet connection on the Operating Unit to connect to the FCNET	When used with DesigoCC Management Station, connection must be in the same room within 20 feet and installed in rigid conduit.
Panel control functions using "Desigo View" (Remote User Interface) *	N	Ability to connect the FACP network using the Ethernet connection on the Operating Unit to permanently connect to the Desigo View.	Not Allowed
Ability to set FDOOT441 and FDOOTC441 detectors sensitivity	Y	FDOOT441 and FDOOTC441 detectors can be configured in the programming tool: 2.50%/ft, 3.00%/ft, 2.50%/ft + Verified, 3.00%/ft + Verified, 3.5%/ft and 3.5%/ft + Verified	Only the <u>Selectable Alarm Threshold Setting Profiles</u> permitted are: 2.50%/ft, 3.00%/ft, 2.50%/ft + Verified, 3.00%/ft + Verified
Ability to set the FDOOTC441 detectors to CO level limit	Y	FDOOTC441 detectors can be configured in the programming tool to define <u>CO level limits</u> in the range of 20ppm – 600ppm (in 10ppm increments)	Minimum selection for <u>CO level limits</u> must be 30ppm
Ability to configure the FDCIO422 for Class A inputs with Open and Short circuit supervision	N	FDCIO422 inputs can be configured for Class A with Open and Short circuit supervision.	Not Allowed
Ability to set the FDCIO422 device to multiple <u>Input Filter Time Setting</u>	Y	FDCIO422 <u>Input Filter Time Setting</u> can be configured in the programming tool : 0.25s, 0.5s, 1s, 2.5s, 5s, 10s, 20s, 45s, 60s, 90s, 120s, 180s, 210s, 240s	Acceptable FDCIO422 <u>Input Filter Time Setting</u> are: 0.25s, 0.50s, 1s
Ability to set the FDCIO422 device to multiple <u>Output Pulse Mode Time Setting</u>	Y	FDCIO422 <u>Output Pulse Mode Time Setting</u> can be configured in the programming tool: 1s, 2s, 3s, 5s, 10s, 20s.	Acceptable <u>Output Pulse Mode Time Setting</u> are: 10s, 20s.
Ability to set the FDCIO422 device to Normally Closed inputs for Class A & Class B wiring	N	FDCIO422 <u>Input Type</u> can be configured to Normally Closed	Not Allowed
Ability for MNS NACs to be configured as <u>Silenceable</u>	N	NACs dedicated for MNS application can be configured as Silenceable	Acceptable-NACs dedicated for MNS application must be configured as Non-Silenceable .
BACnet client Supervision timeout to delay reporting network supervision.	Y	Ability for the BACnet supervision timeout to be configured from 1s to 10 minutes.	Acceptable Range must be between 1 sec and 85 sec.

DACT Alarm, Trouble Supervisory Retransmission interval	Y	DACT retransmission intervals can be configured up to 24 hours	DACT retransmission intervals must be configured up to 6 hours
Loss of primary power - Door unlocking timing	Y	Fire Control can be user defined accordingly	Fire control to be configured to within 10 minutes "unlocking" after loss of primary power
Releasing operation - Door release operation timing	Y	Releasing Control Group can be user defined accordingly	Releasing Control Group to be configured to 60 secs. Max release
Interconnected/networked panel loops pathway configuration	Y	Interconnected/networked loops could be configured Class X, A or B	Configuring Class X network loops via the Redundancy management configuration setting
Alarm verification restart time	Y	Alarm verification restart time user defined	Max restart time shall not exceed 30 seconds when accomplished on a multiple circuit (zone) or system basis
Alarm verification configuration	N	Alarm verification devices in a cross-zone operation	Alarm verification shall not be used in initiating device circuits intended for cross-zone operations
CO alarm tone programming	Y	CO programming tone user defined	CO detector MUST be programmed as Temporal 4
PAD-5 Trouble supervision	Y	Trouble supervision setting can be on or off	Error reporting must be "on" and activated
PAD-5 Ground Fault monitoring	Y	Ground fault supervision for the power supply can be activated or turned off	Ground fault supervision must be "on" and activated
Signal Silence Inhibit Feature	Y	Signal Silence Inhibit range 0-30 minutes	UL minimum is 3 minutes

Table 2: Limitations and Restrictions per CAN/ULC-S527 3rd Ed. Amd 1 cl. 7

Notice to Users, Installers, Authorities Having Jurisdiction (AHJ) and Other Involved Parties			
This product incorporates field-programmable software. In order for the product to comply with the requirements in CAN/ULC-S527, Standard for Control Units for Fire Alarm Systems, certain programming features or options must be limited to specific value or not used at all as indicated below.			
Program Feature or Options	Permitted in CAN/ULC-S527? (Y/N)	Possible Settings	Setting Permitted in CAN/ULC-S527
Ability to change the volume for the sounder on the FACP	Y	Adjustment of the sounder volume on the Operating Unit Menu ranges from Loud to Max to Low to Min to Bypassed	Setting of the <u>Sounder Volume</u> must be greater than " Bypassed " setting. Default must be set to Max
Global Access Point (GAP) using Ethernet connection *	Y	Ability to connect the FACP network using the Ethernet connection on the Operating Unit to connect to the FCNET	When used with DesigoCC Management Station, connection must be in the same room within 20 feet and installed in rigid conduit.
Panel control functions using "Desigo View" (Remote User Interface) *	N	Ability to connect the FACP network using the Ethernet connection on the Operating Unit to permanently connect to the Desigo View.	Not Allowed
Ability to set FDOOT441 and FDOOTC441 detectors sensitivity	Y	FDOOT441 and FDOOTC441 detectors can be configured in the programming tool: 2.50%/ft, 3.00%/ft, 2.50%/ft + Verified, 3.00%/ft + Verified, 3.5%/ft and 3.5%/ft + Verified	Only the <u>Selectable Alarm Threshold Setting Profiles</u> permitted are: 2.50%/ft, 3.00%/ft, 2.50%/ft + Verified, 3.00%/ft + Verified
Ability to set the FDOOTC441 detectors to CO level limit	Y	FDOOTC441 detectors can be configured in the programming tool to define <u>CO level limits</u> in the range of 20ppm – 600ppm (in 10ppm increments)	Minimum selection for <u>CO level limits</u> must be 30ppm
Ability to configure the FDCIO422 for Class A inputs with Open and Short circuit supervision	N	FDCIO422 inputs can be configured for Class A with Open and Short circuit supervision.	Not Allowed
Ability to set the FDCIO422 device to multiple <u>Input Filter Time Setting</u>	Y	FDCIO422 <u>Input Filter Time Setting</u> can be configured in the programming tool : 0.25s, 0.5s, 1s, 2.5s, 5s, 10s, 20s, 45s, 60s, 90s, 120s, 180s, 210s, 240s	Acceptable FDCIO422 <u>Input Filter Time Setting</u> are: 0.25s, 0.50s, 1s
Ability to set the FDCIO422 device to multiple <u>Output Pulse Mode Time Setting</u>	Y	FDCIO422 <u>Output Pulse Mode Time Setting</u> can be configured in the programming tool: 1s, 2s, 3s, 5s, 10s, 20s.	Acceptable <u>Output Pulse Mode Time Setting</u> are: 10s, 20s.
Ability to set the FDCIO422 device to Normally Closed inputs for Class A & Class B wiring	N	FDCIO422 <u>Input Type</u> can be configured to Normally Closed	Not Allowed

Ability for MNS NACs to be configured as <i>Silenceable</i>	N	NACs dedicated for MNS application can be configured as <i>Silenceable</i>	Acceptable-NACs dedicated for MNS application <u>must</u> be configured as <i>Non-Silenceable</i>
BACnet client Supervision timeout to delay reporting network supervision.	Y	Ability for the BACnet supervision timeout to be configured from 1s to 10 minutes.	Acceptable Range must be between 1 sec and 85 sec.
DACT Alarm, Trouble Supervisory Retransmission interval	Y	DACT retransmission intervals can be configured up to 24 hours	DACT retransmission intervals must be configured up to 6 hours
Loss of primary power - Door unlocking timing	Y	Fire Control can be user defined accordingly	Fire control to be configured to within 10 minutes "unlocking" after loss of primary power
Releasing operation – Door release operation timing	Y	Releasing Control Group can be user defined accordingly	Releasing Control Group to be configured to 60 secs. Max release
Interconnected/networked panel loops pathway configuration	Y	Interconnected/networked loops could be configured Class X, A or B	Configuring Class X network loops via the Redundancy management configuration setting
Alarm verification restart time	Y	Alarm verification restart time user defined	Max restart time shall not exceed 30 seconds when accomplished on a multiple circuit (zone) or system basis
Alarm verification configuration	N	Alarm verification devices in a cross-zone operation	Alarm verification shall not be used in initiating device circuits intended for cross-zone operations
CO alarm tone programming	Y	CO programming tone user defined	CO detector MUST be programmed as Temporal 4
PAD-5 Trouble supervision	Y	Trouble supervision setting can be on or off	Error reporting must be "on" and activated
PAD-5 Ground Fault monitoring	Y	Ground fault supervision for the power supply can be activated or turned off	Ground fault supervision must be "on" and activated
Signal Silence Inhibit Feature	Y	Signal Silence Inhibit range 0-30 minutes	ULC minimum is 5 minutes

Minimum Requirement to Access FS920 documents

- Computer with high speed internet connection
- Microsoft Explorer 7.0 or higher
- Adobe Reader (<http://www.adobe.com/>)

If you cannot meet these requirements, please contact Siemens Technical Support at 1-800-248-7976 to request hard copy of the installation guidelines.

Location of the FS920 User Documentation

To access the FS920 documentations, go to

<https://extranet.w3.siemens.com/buildingtechnologies/partner/FSUSENV3/Pages/default.aspx>. Click "Search Documentation". Enter the appropriate document number in the "Search for" dialog box to access, and then click "Search".

The screenshot shows a web browser window with the URL extranet.w3.siemens.com/buildingtechnologies/partner/FSUSENV3/Pages/default.aspx. The page features a Siemens logo and a navigation menu on the left with items like Home, Fire Products, Technical Support, Documentation, Sales Support, Programs, Training, Ordering, News, and Events. A central carousel displays a 'Cerberus PRO Voice 252/504 pt panel MP2.2' with the text: 'Cerberus PRO Fire Alarm Control Panels for Fire & Voice with new features and enhancements to support all markets served by UL® and ULC®'. On the right, there are sections for 'Protection Matters: Fire Safety News' with links to quarterly reports, 'Siemens Fire Safety- Key Contacts', and 'Events'.

Select the appropriate document by double clicking it. It is recommended to save these documents in your computer for future access. Select the "Save" button to store the document in your computer.

Table 3: FS920 Document Description

Document Description	Doc Number	Description
FS920 System Description	A6V10333401	Overview of the FS920 system structure and functions
FS920 Planning	A6V10333396	Provides information on project planning for the system and the individual devices.
FS920 Mounting, Installation, Product Data	A6V10333409	Provides HW reference document. This contains the wiring connections, electrical rating, module settings and compatible accessories for each individual module. Provides detailed description on how each module is installed in the enclosure and how internal and external wiring are routed.
FS920 SLC Device Compatibility List	A6V10332926	Provides the list of compatible devices that can be connected to the signaling line circuit (such as detectors, etc.)
FS920 SLC Device Compatibility List (Canada)	A6V10399676	Provides the list of compatible devices that can be connected to the signaling line circuit (such as detectors, etc.)
FS920 Commissioning, Maintenance, Troubleshooting	A6V10333434	Instructions for commissioning, maintenance and troubleshooting of the whole fire detection system.
FS920 Configuration	A6V10333423	Provides instructions how to use Cerberus-Engineering-Tool Configuration Tool to configure and program the system.
FC20xx / FT924 Operation Manual	A6V10333380	Provides the detailed operating instructions of the system after it has been configured
FS920 NAC Compatibility List	A6V10333532	Provide the list of compatible devices that can be connected to the Notification Appliance Circuit.
FS920 Fire System Integration Guide	CM10013en0F	Describes the FS20 Protection Integration including the configuration steps of FC20 fire alarm control panels.

Introduction

The FS920 system is a life safety network that is modular, networkable fire detections system that can consist of FC922, FC924 Fire control panels and FT924 Fire terminal. It comprises of all the components required for the detection, evaluation and annunciation of life safety event such as fire and smoke conditions. By using optional modules, copper wiring and/or Fiber Optic cables are used to network the panels together.

The FC922 is capable of supporting up to 252 devices and FC924 is capable of supporting up to 504 devices. Both panels have a PMI with optional LED module, 2 Class B or 1 Class A NAC (expandable to 4 Class B, 2 Class A NACs), 4 control relays, Battery Charger, Aux Power connection and optional capability for connection to Leased Line or City Tie. Both panels support DACT, connection to Remote Printer / Remote Annunciators and Releasing Application as optional feature. Both panels use 170W power supply or optional 300W power supply for more power capability.

The PAD-5 is an addressable booster power supply which offers additional NAC expansion with flexible configuration for each individual circuit. The PAD-5 also includes releasing circuits and conventional zone inputs.

The FV922 and FV924 Fire voice control panels have all the capabilities and features of the FC922 and FC924 plus voice evacuation capabilities that support Mass Notification and Emergency evacuation. Both panels have Voice Card Cage, which, can support up to 3 amplifier circuits which, can be configured as Class A or Class B (3 primary and 1 backup, or 2 primary and 2 backup), connection LED/Switch module and optional capability for connection to remote/local microphone, remote LED/Switch module and low level input/output audio. It has the ability to originate and broadcast voice announcements through connected speakers and transfer voice announcement among interconnected systems. Both the FV922 and the FV924 are powered by either a single or two cascaded 300W power supplies. For Mass Notification Application, it has the security level stated below:

- Communication Security → Level 1 (Security function not employed)
- Stored Data Security → Level 0 (Passwords are employed)
- Access Control Security → Level 1 (Passwords are employed with programmable time-out feature)
- Physical Security → Level 1 (keylocks are employed to control physical entry to the panel)

The FT924 is a network terminal capable of displaying events for the entire system or can be programmed to control and display a specific panel.

The VR2005 Remote microphone is a remote voice station that utilizes remote terminal board and can have microphone and LED/switch modules connected to the FV922 or FV924 to enable fire safety personnel to originate voice announcements remotely. The FV922/FV924 can power and control up to four VR2005 remote microphone stations per node. Refer to the VTA2001-A1 installation instructions, Document ID A6V10405564, for installation information.

The FT924 panel and remote microphone can be combined in a 2HU enclosure (2HU Remote Station) by utilizing its respective interface units and remote switch module. Refer to Figure 5 for connection and recommended wiring routes.

The FV922/FV924 Voice Systems, when used in conjunction with Siemens Hi-Fidelity speakers, meet the requirement for low frequency signal tone as described in the section for Determination of Low Frequency Signal Format, in UL464, Standard for Audible Signal Appliances, suitable for sleeping areas as required by NFPA 72 Chapter 18.4.5 (2013 Edition). Refer to Document ID A6V10333532 for compatible speakers.

The FV922/FV924 also supports Background music and Convenience paging functionalities using Global analog audio input that is configured for lowest priority. Refer to the FS920 Configuration manual, Document ID A6V10333423, Section 11.6.5 and the FS920 Operation Manual, Document ID A6V10333380, Section 8.7 for proper configuration and operation.

For a complete FS920 system overview, refer to the FS920 System Description, Document ID A6V10333401.

Legacy Migration

The FC922/FC924 fully supports Siemens legacy systems and technology. With the use of the FCL2004-U1 module, the Cerberus PRO panel offers full compatibility with legacy MXL and MXL-IQ system peripheral devices. Each Cerberus PRO system will support up to two FCL2004-U1 modules. Each module has two ALD circuits for a total of 240 MXL compatible devices (120 per module), in addition to the Cerberus PRO peripherals already available. Also available are the MXL-IQ mechanical migration kits. The kits support existing MXL-IQ backboxes MSE-3L and MSE-3M. Reuse the existing enclosure and replace the electronics with new Cerberus PRO system panel electronics.

Remote Connectivity

The FC922/924 and FV922/924 can send events via the Connect X300 gateway for remote diagnostics and serviceability. The Connect X300 can be installed as a node on the FCnet or FVnet.

Installation

The FC922, FC924, FT924, FV922, FV924 and VR2005 panels are installed in dry, protected environments using different enclosures that consist of backbox, inner door and outer door that is lock-protected and have clear plexiglass windows. The FV922 and FV924 panels use 3-Height enclosure units; the FC922 and FC924 panel use 2-Height enclosure units and the FT924 and VR2005 use 1-Height enclosure units. All the modules are installed inside the enclosure backbox and inner doors (refer to Figure 3). An optional DIN Rail Kit is available (PN: S54400-B44-A1) to allow indirect wiring connection to the PMI and other modules that support low power field wiring. An optional Battery Seismic Kit (PN: S54400-B43-A1 or S54400-B55-A1) to meet the seismic requirement. An optional Battery Disconnect module is available (S54400-B145-A1) is available to meet ULC requirements. An optional Ethernet Switch Module (S54400-B152-A1) is available to allow the FC920/FC924/FT924 panels to be networked with FV922/FV924.

To support migration from legacy installations, the use of the FHA2056-U1/-R1 is recommended (PN: S54400-B18-A1 [Black] or S54400-B19-A1 [Red]).

For complete module mounting and installation, please refer to the FS920 Mounting, Installation and Product Data manual, Document ID A6V10333409.

Wiring

For FS920 System wiring, refer to the applicable module section of the FS920 Mounting, Installation and Product Data manual, Document ID A6V10333409, and module installation instructions.

External FS920 System Wiring

FCNET – Refers to communication connection between panels using SafeDLink module (S54400-A60-A1) and/or Fiber network modules (FN2006-U1 / FN2007-U1). This can be configured as Class A and B and is supervised. Refer to the FS920 Mounting, Installation and Product Data manual, Document ID A6V10333409, for proper wiring connection.

RS485 Remote Peripheral (UFP) – connection of the FACP to the Remote display (FT2014-U3, FT2014-R3), Remote terminal (FT2015-U3, FT2015-R3), Remote Peripheral Module (FCA2018-U1), LED Annunciator Driver (FT2007-U1), Tabular annunciator 16 Zone (FT2008-U1/FT2008-R1), Tabular annunciator 32 Zone (FT2009-U1/FT2009-R1), and Graphic driver (I/O) (FT2003-U1) through the RS485 class A module (isol.) (FCA2016-A1). This can be configured as Class A and B and is supervised. Refer to the FS920 Mounting, Installation and Product Data manual, Document ID A6V10333409, for proper wiring connection.

FDNET – Signaling Line Circuits (SLC) that used P2 proprietary protocol connection of the FACP to the Initiating Devices such as Detectors, Monitor switches, etc., through the Periphery board (250p/500p) (FCI2016-U1, FCI2017-U1). This can be configured as Class A, B, or X and is supervised. Refer to the FS920 Mounting, Installation and Product Data manual, Document ID A6V10333409, Section 25, for proper wiring connection and compatible devices. A full portfolio of peripheral devices with optional built-in isolation including the PAD-5 is available for use on the FDNET.

Notification Appliance Circuit (NAC) – This is the connection of FACP to the Notification Appliances devices through the Periphery board (250p/500p) (FCI2016-U1, FCI2017-U1) or optional NAC module (FCI2011-U1). This can be configured as Class A or Class B and is supervised. Refer to the FS920 Mounting, Installation and Product Data manual, Document ID A6V10333409, for proper wiring connection and Document ID A6V10333532 for List of Compatible NAC Devices.

Releasing Circuit – This is the connection of the FACP to releasing devices such as solenoids and squibs through the optional Releasing module (XCI2001-U1). This is configured as Class B or Class A, and is supervised. The releasing application meets the requirement for the following regulation: NFPA 13, NFPA 750, NFPA 2010, NFPA 2001.

Refer to the FS920 Mounting, Installation and Product Data manual, Document ID A6V10333409, Section 22, for proper wiring connection. Refer to the Solenoid Compatibility List, Document ID A6V11620059.

VCNet Connections – Refers to the communication connection between Voice panels using Ethernet Modules (VN2001-A1, VN2002-A2, VN2003-A3). This can be configured as Class B or X and is supervised. Refer to the FS920 Mounting, Installation and Product Data manual, Document ID A6V10333409, for proper wiring connection.

CAN Circuits – connection of the Voice panels to remote or local CAN modules (VTO2001-U3, VTO2004-U3, VCI2001-U1). This can be configured as Class B. Refer to the FS920 Mounting, Installation and Product Data manual, Document ID A6V10333409, for proper wiring connection.

Ethernet Connections – This is the internal connection of the Card cage (4 amplifiers) (VCA2002-A1) to the Op. unit bracket UL (option) (FCM2025/2050-A1) and VCNET connection of the FV922/2050 Fire voice control panel. For inter-connection between FC922/FC924 and FV922/FV924, the Ethernet switch (modular) (FN2012-A1, S54400-B152-A1) must be used. The Ethernet connections can be configured as Class B or X and is supervised. For proper wiring connection, refer to the FN2012-A1 Installation Instructions, Document ID A6V10407862.

Audio Input/Output – This is the internal and external connection of audio inputs from microphones and connected audio systems. All audio inputs and outputs are Class B and are supervised. Refer to the FS920 Mounting, Installation and Product Data manual, Document ID A6V10333409, for proper wiring connection.

Speaker Circuits – This is the external connection of amplified audio to the speaker lines. These can be configured as Class A, Class B or Dual-interleaved Class B and are supervised. Refer to the VCI2001-U1 Voice amplifier card (25V) Installation Instructions, Document ID A6V10370410, for proper wiring connection. Up to 24 HCP intelligent control points can be used in speaker zones and can be configured as Class A or Class B. Refer to the HCP installation instructions, P/N 315-034860 for more information.

Compatible Solenoids – Refer to the Solenoid Compatibility List, Document ID A6V11620059.

Note: The Manual Discharge function always overrides the Abort switch function.

Leased line/city tie mod. – This is the connection of FACP to the Leased Line or City Tie through optional LLCT Module (FCI2020-U1). This is configured as Class B only and is supervised only when configured as City Tie. Refer to the FS920 Mounting, Installation and Product Data manual, Document ID A6V10333409, Section 23, for proper wiring connection.

Central/Remote Station – The FACP uses the Dialer module (DACT) (FCA2015-U1) connected to the PSTN to connect to the central or remote station in the event of life safety situation. Connections to phone lines are supervised. Refer to the FS920 Mounting, Installation and Product Data manual, Document ID A6V10333409, for proper wiring connection.

For Canadian Installations, the following applies:

- **Both** the Dialer module (DACT) (FCA2015-U1) and the 3rd party communicator must be configured and connected to the same Central Station.
- One of the User-Defined buttons on the Operating Unit **must** be programmed as ***Manual Alarm Signal (evacuation) Control, which*** is able to initiate alarm signal and resound audible devices after they have been silenced. The button chosen must be clearly marked on the Inscription Strip.
- The Battery disconnect module (FCA2032-U1) is required to disconnect the battery when voltage drops below 19 VDC while system is on battery power.
- If using an Remote display/Remote terminal (FT2014-U3 or FT2015-U3) the Inner Door RDT (black) (FHD2012-U1) is required to meet ULC audible indicator sound output requirements.

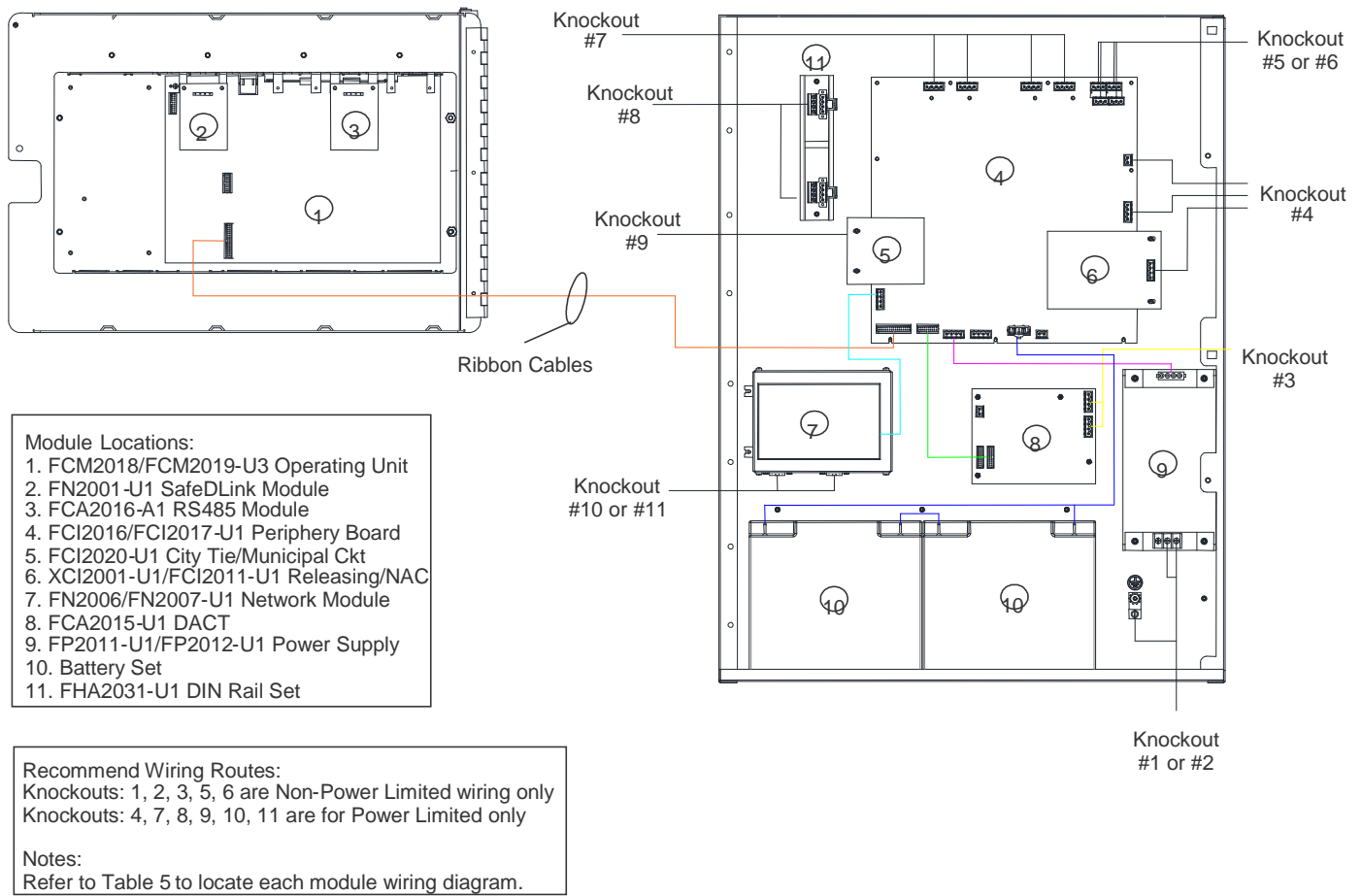

Figure 1: Module Location in 2HU Enclosure and Recommended Wire Routing

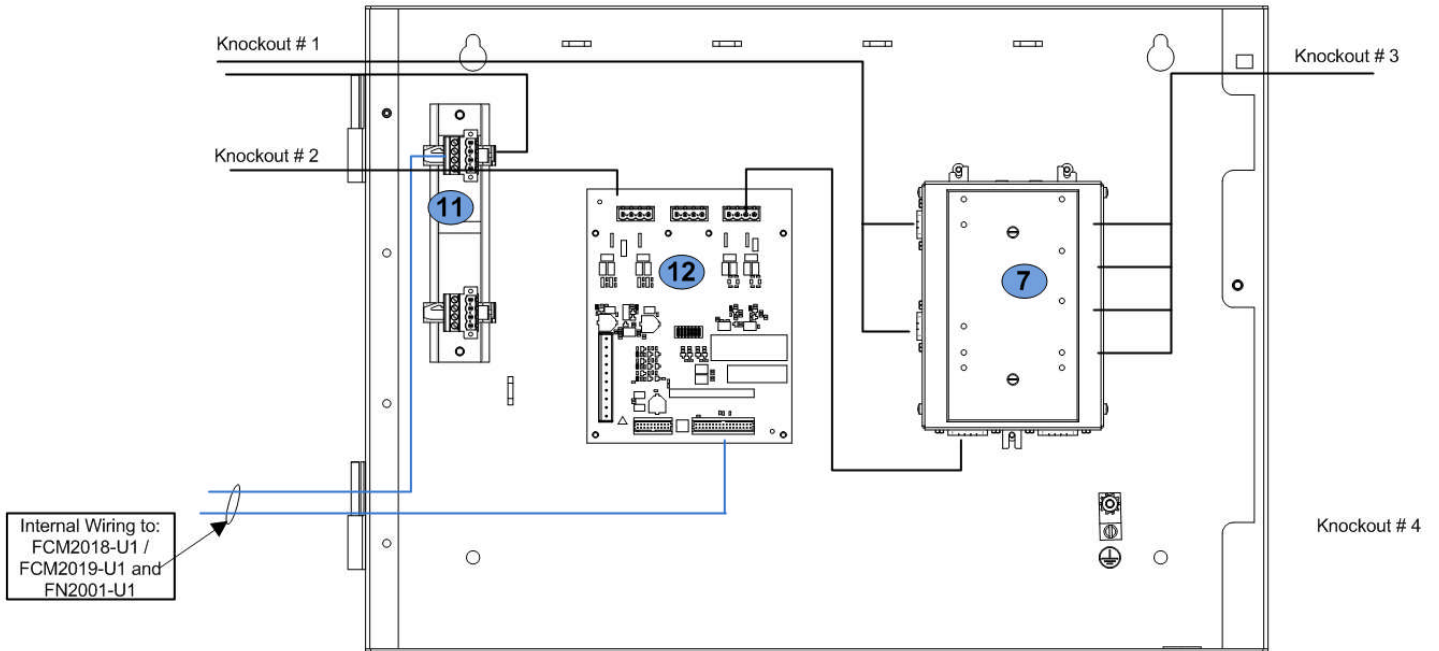

Figure 2: Module Location in 1HU Enclosure and Recommended Wire Routing

Modules Location in FHB2001-U1/R1

- 7 – FN2006-U1 /FN2007-U1
- 11- FHA2031-U1
- 12 – FTI2001-U1

Recommended Wiring Routes:

- Knockouts: 1, 2, 3, 4 are for Power Limited wiring only
- Notes: Refer to Table 5 to locate each module wiring diagram.

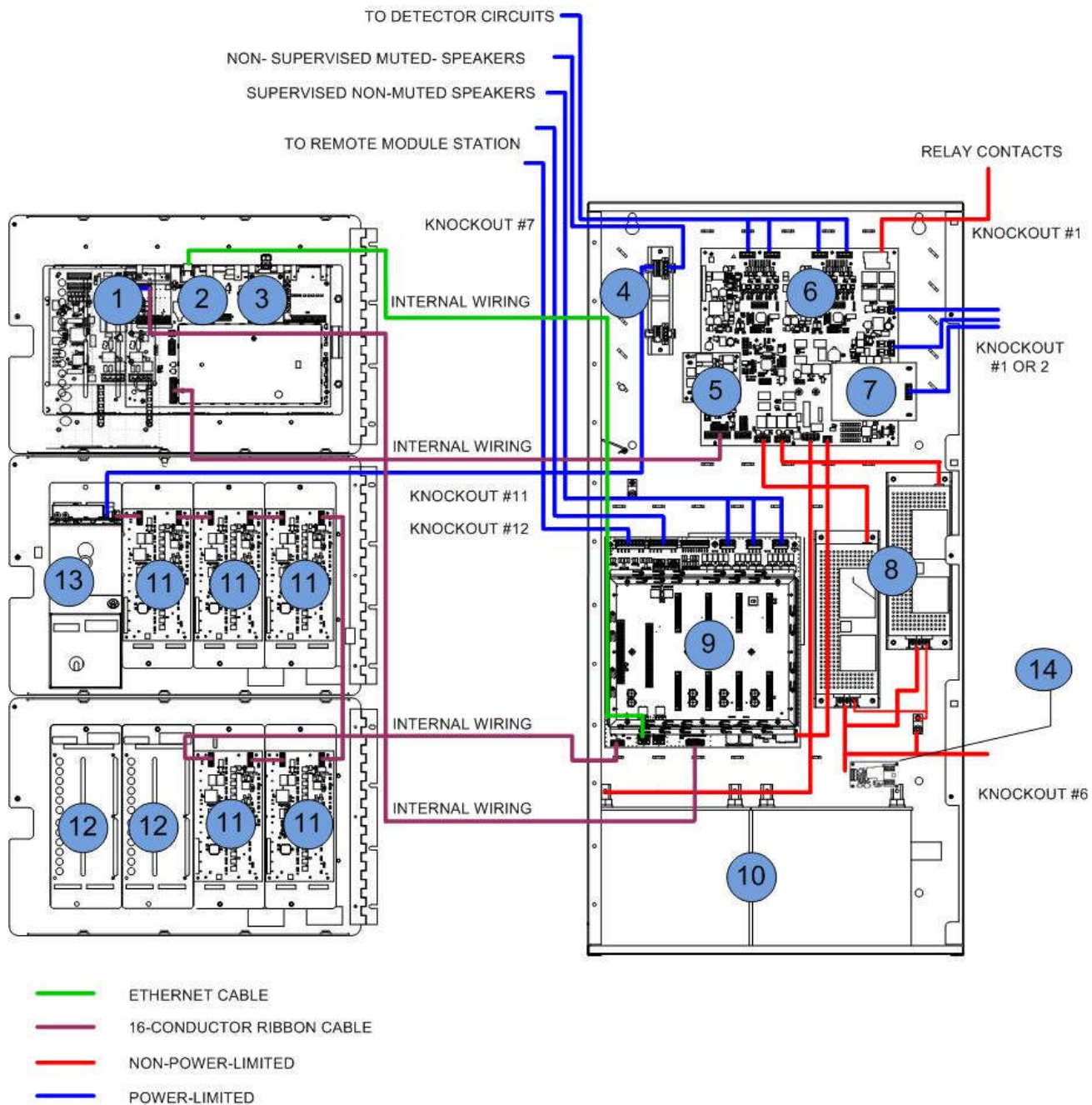

Figure 3: Module Location in 3HU Enclosure and Recommended Wire Routing

Module Locations

- | | |
|-----------------------------|--------------------------------------------------------------|
| 1. FCA2015-U1 | 8. FP2013-U1 |
| 2. FCM2018/FCM2019-U2/U3 | 9. VCA2002-A1 [contains: VCI2001-U1, VCC2001-A1, VCC2002-A1] |
| 3. FCA2016-A1 | |
| 4. FHA2031-U1 | 10. Battery set |
| 5. FCI2020-U1 | 11. VTO2001-U2/U3 |
| 6. FCI2016/FCI2017-U1 | 12. FCM2022-U2/U3 |
| 7. FCI2011-U1 or XCI2001-U1 | 13. VTO2004-U2/U3 |
| | 14. FCA2032-U1 |

Recommended Wiring Routes

- Knockouts 1 and 6 are for non-power limited wiring.
- Knockouts 2, 7, 10, 11, 12 are for power limited wiring.

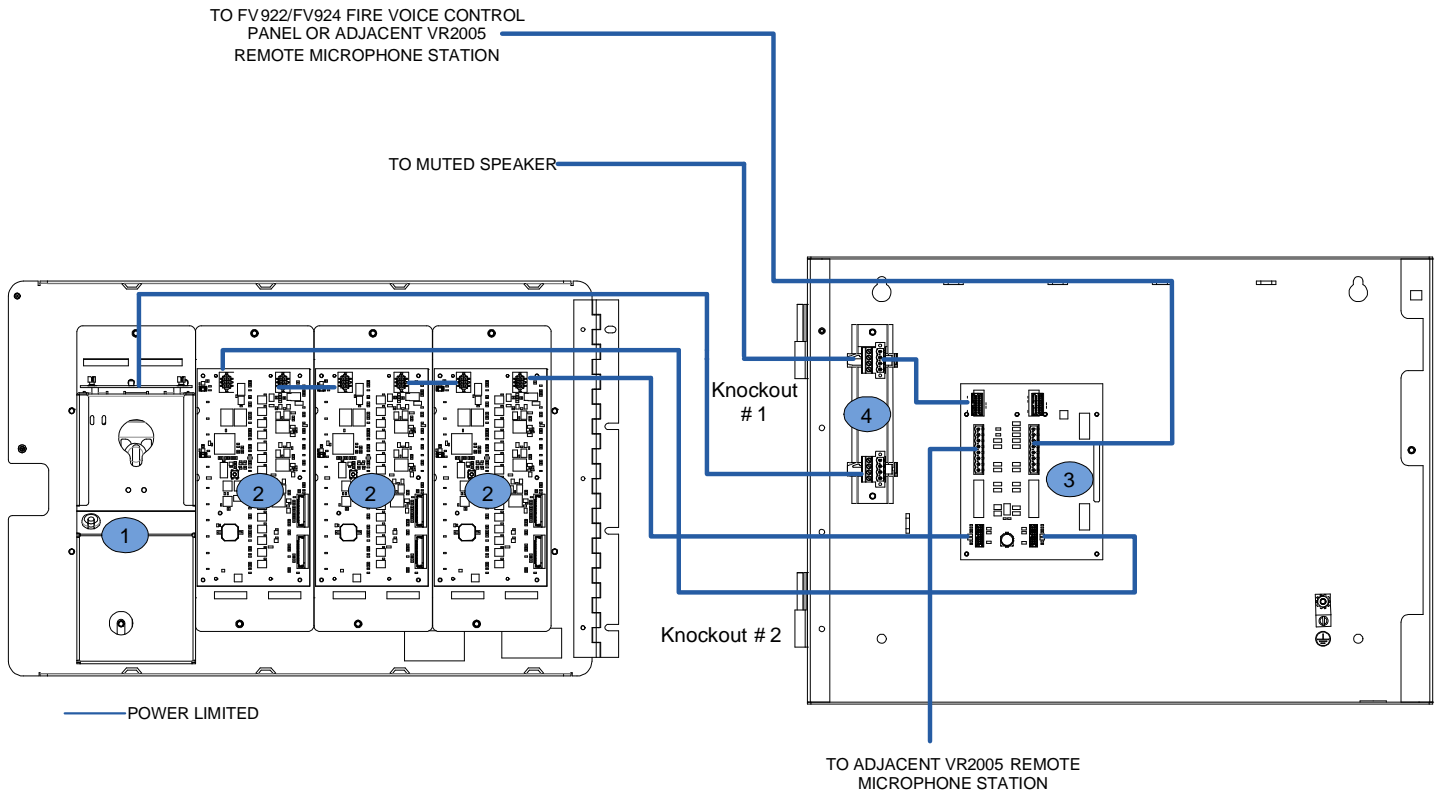

Figure 4: Module Location in 1HU Remote Microphone Station and Recommended Wire Routing

- Module Locations:**
1. VTO2004-U2/U3
 2. VTO2001-U2/U3
 3. VTA2001- A1
 4. FHA2031-U1 (optional)

Recommended Wiring Routes:

Any knockouts may be used for the power-limited wiring associated with the Remote Microphone.

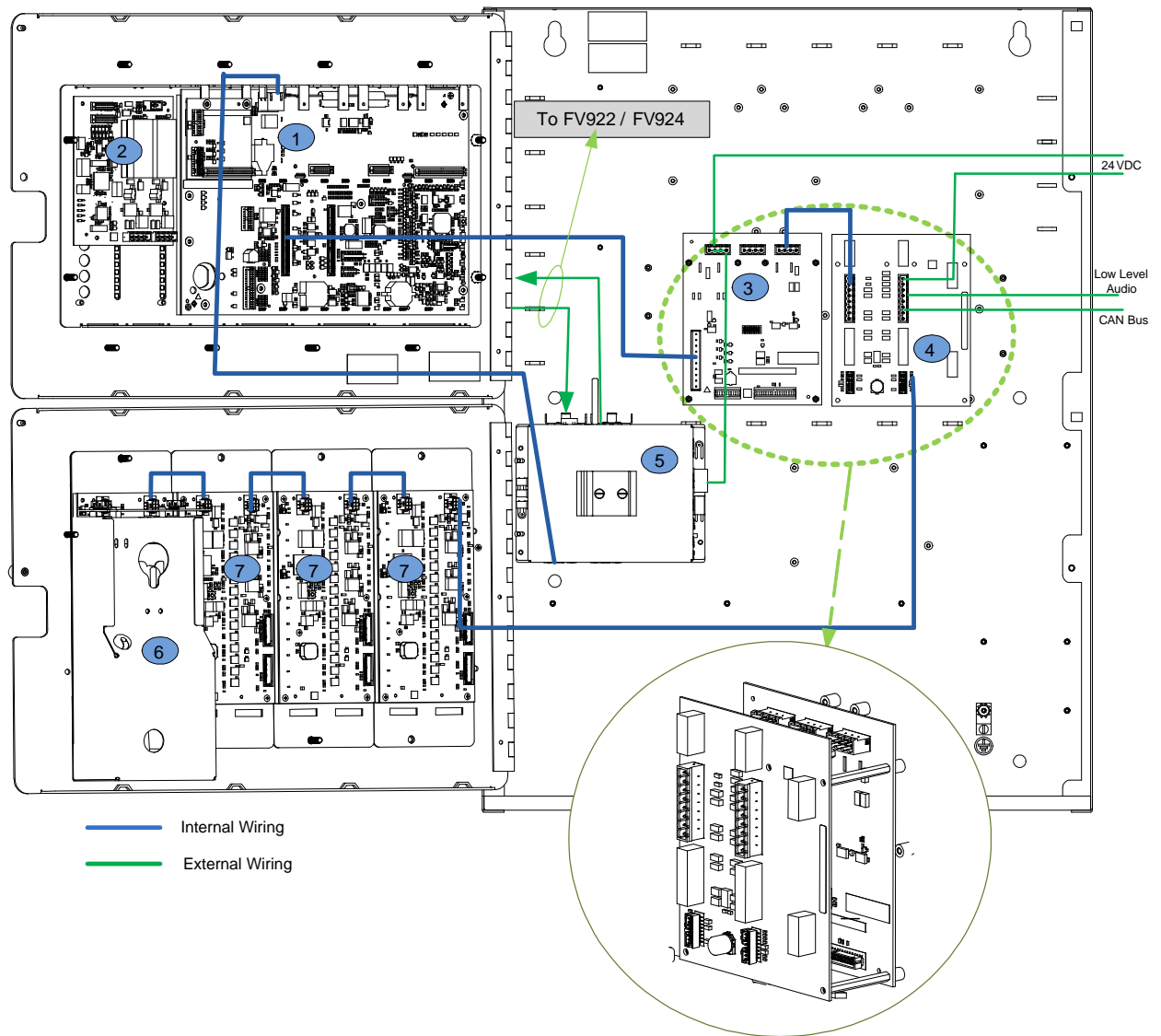

Figure 5: Module Location for 2HU Enclosure (Remote Station) and Recommend Wiring Routing

Module Locations FHB2002-U3/R3:

1. FCM2018-U3 / FCM2019-U3
2. FCA2015-U1 (optional)
3. FTI2001-U1
4. VTA2001-A1
5. FN2012-A1 with VN2001-A1 / VN2002-A1 / VN2003-A1
6. VTO2004-U2/U3
7. VTO2002-U2/U3

Recommended Wiring Routes:

Any knockouts may be used for the power-limited wiring associated with the 2HU - Remote Station.

Notes:

As indicated in Figure 5, FTI2001-U1 and VTA2001-A1 are stacked on top of one another using the standoff provided with VTA2001-A1. It is shown flat for ease of layout.

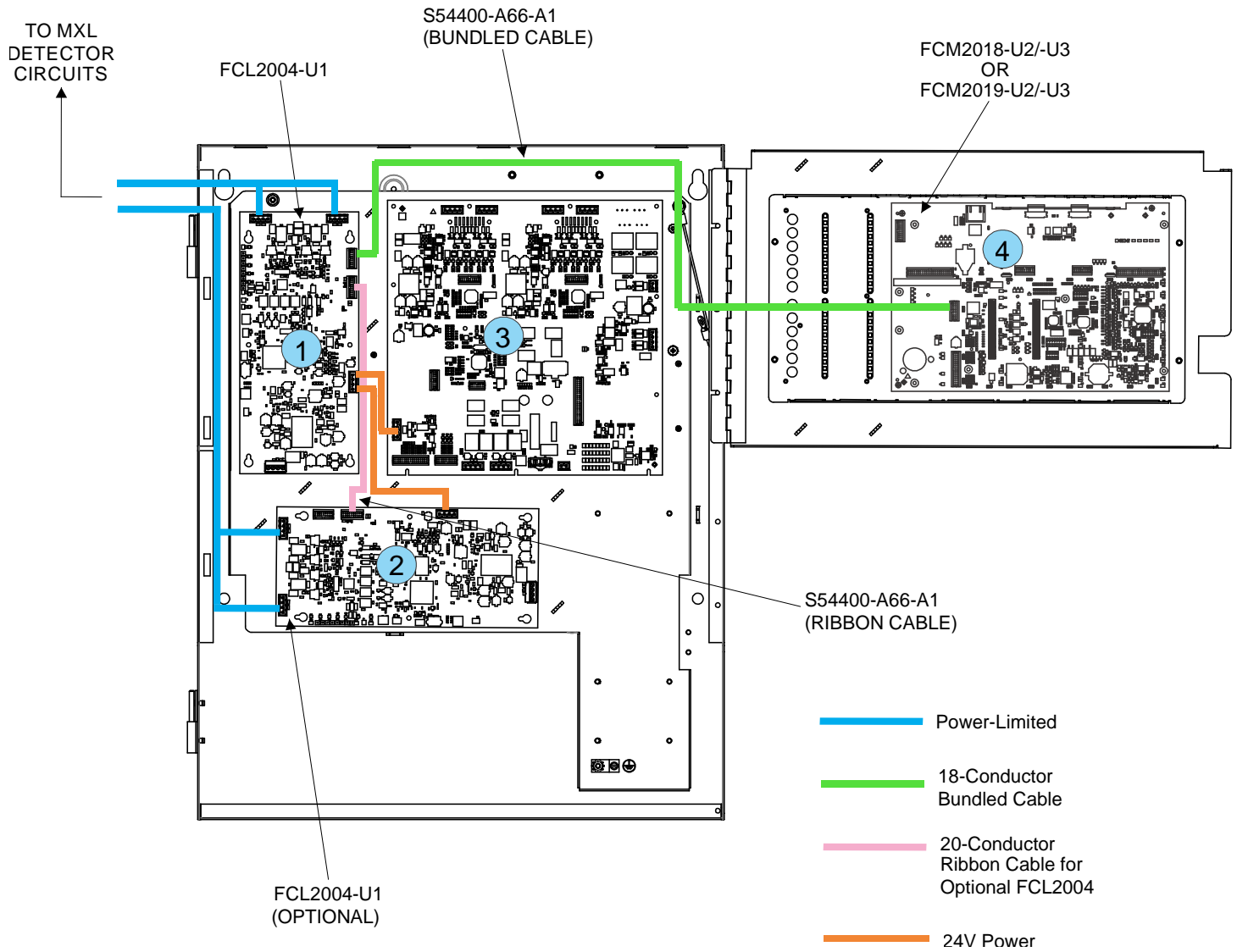

Figure 6: Module Location in MXL-IQ MSE-3L Enclosure and Recommended Wire Routing

Module Locations in MSE-3L Enclosure using Adapter Plate (P/N A5Q00075220):

1. FCL2004-U1
2. FCL2004-U1 (optional)
3. FCI2016/FC2017-U1
4. FCM2018/FCM2019-U2/-U3

Notes:

To install an FCL2004-U1 module in a MSE-3L enclosure, install a FHA-MIQKIT-04 (Black) or FHA-MIQKIT-05 (Red).

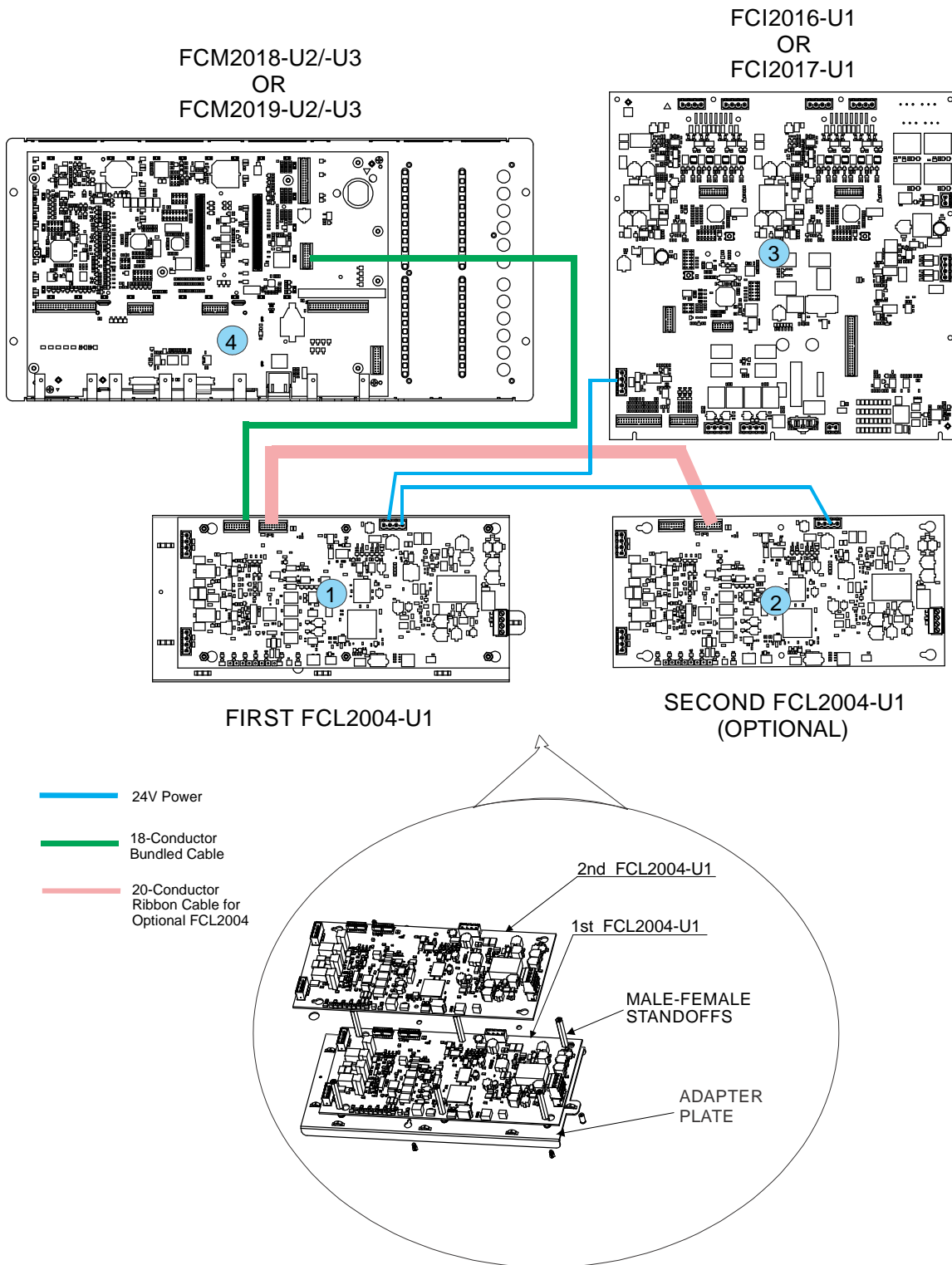

Figure 7: Module Location in 2HU Enclosure and Recommended Wire Routing

Module Locations in 2HU Enclosure using Adapter Plate (P/N A5Q00079811):

1. FCL2004-U1
2. FCL2004-U1 (optional)
3. FCI2016/FC2017-U1
4. FCM2018/FCM2019-U2/-U3

Notes:

For mounting the FCL2004-U1 module(s) in a 2HU enclosure, refer to the FCL-MXLPLATE Installation Instructions, Document ID A6V11877890.

FS920 General Electrical Characteristics

Refer to the FS920 Mounting, Installation and Product Data manual, Document ID A6V10333409, for circuit electrical characteristics.

System Power Input → Output:

FP2011-U1: 120 VAC, 60 Hz, 50 Hz, 1.64 A (max); 240 VAC, 50 Hz, 60 Hz, 1.5 A (max) → 24 VDC @ 6.5 A (max)

FP2012-U1: 120 VAC, 60 Hz, 50 Hz, 2.77 A (max); 240 VAC, 50 Hz, 60 Hz, 1.37 A (max) → 24 VDC @ 11.5 A (max)

FP2013-U1: 120VAC@ 5.0A (max), 240VAC, 2.5A (max) → 24VDC @ 20A (max, combined output for both units)

Ground Fault Threshold: 1k Ohms (0.1 Ohm for Leased Line Circuit)

Wire to wire fault impedance threshold = 0 Ohms

Wire to wire open impedance threshold = Infinite impedance

Battery: 24VDC Lead acid batteries only. 100Ahr (max), Charge Voltage/Current: 27.5VDC, 6A (max)

Table 4: Battery Sets

<u>Model Number</u>	<u>Part Number</u>	<u>Description</u>
BP-61	175-387194	24V 18AH (min.) – Battery set
BTX-1	175-083897	24V 33AH (min.) – Battery set
BTX-2	175-350784	24V 55AH (min.) – Battery set
BTX-3	175-034219	24V 100AH (min.) – Battery set

SLC: 35V @ 500mA (max), max line impedance: 180 ohms, Class B, A, X. All SLC are supervised. Refer to Document ID A6V10332926 (U.S.) or A6V1039976 (Canada) for Compatible devices.

NAC: 24VDC, 0.3A (max) Regulated for Pulsing Loads; 24VDC, 3.0A (max) Special Application for pulsing loads, Regulated for non-pulsing loads, Class A or Class B, Coded or Non-coded, Synchronized, refer to Document ID A6V10333532 for compatible NAC devices. Only combination MNS NACs and Fire NACs are allowed.

Relay Contacts: 30VDC, 120ADC, 5A, Common (Alarm, Supervisory, Trouble) and Programmable (User-defined)

Releasing Circuit: 24VDC, 2A(max), Class B or Class A. Refer to the Solenoid Compatibility List, Document ID A6V11620059.

Aux Power: 24VDC, 1.5A (max), Power Limited, Special Application

DC Supervision (optionally selectable): 18VDC max

CAN Bus: max line impedance: 15 ohms, Class B, Supervised.

Speaker Circuit:

Output Voltage: 25Vrms or 70Vrms

Max Power Output: 65W @ 70Vrms, 50W @ 25Vrms (refer to Document ID A6V10370410 for resistance limitations)

Frequency Response: 400Hz – 4kHz

Total Harmonic Distortion (THD): <0.4% nominal @ 1kHz

Efficiency (under full load): 85% @ 70Vrms, 80% @ 25Vrms

Voice Intelligibility: The FS20 System meets Voice Intelligibility Requirement as defined in section D of the NFPA 72, 2010 edition, having a Speech Transmission Index (STI) of 0.50 or greater. Each acoustically distinguished space must be properly evaluated and tested to ensure compliance.

Pathway Survivability: Each circuit must be evaluated and tested to ensure compliance to the application and area of protection to meet the criteria of Section 12.4 of NFPA 72, 2010 edition.

All wiring between the releasing device and any other interconnected product shall be monitored for integrity in accordance with the Common Performance and Monitoring for Integrity – Protected Premises Units/Systems.

Any SLC pathway shall have the capability, either inherent or by use of external devices, to prevent a wire to wire fault from affecting the entire pathway.

NOTE 1: Reference to Power Limited is deemed Class 2 for U.S. installation only. Reference to Power Limited 70V speaker circuits is deemed Class 3 for U.S. installation only. For Canadian installations, the same circuits employed by the product aren't deemed Class 2 nor Class 3. Please refer to the appropriate product installations for further details.

NOTE 2: Where power to a device or appliance is supplied over a separate pathway from the initiating device, notification appliance, and/or signaling-line circuit(s), the operation of the power pathway shall meet the performance requirements of the initiating device, notification appliance, and/or signaling-line circuit(s) and the power circuit shall be defined by the applicable class in the product installation wiring diagram/instructions.

**FS920 Module Description -
Table 5: Installation Instruction Part Numbers**

Model Number	Part Number	Description	Product Insert Number
FCM2018-U3	S54400-C40-A2	Operating unit	A6V10315030
FCM2019-U3	S54400-C41-A2	Operating unit (+ LED)	A6V10315030
FCI2016-U1	S54400-A55-A1	Periphery board (250p)	A6V10315038
FCI2017-U1	S54400-A56-A1	Periphery board (500p)	A6V10315038
FCI2011-U1	S54400-A54-A1	NAC module (1A/2B)	A6V10315036
FCI2020-U1	S54400-A57-A1	Leased line / city tie mod.	A6V10334256
FTI2001-U1	S54400-A58-A1	Fire terminal board	A6V10315040
FP2011-U1	500-450222	Power supply (170W)	A6V10333499
FP2012-U1	S54400-Z60-A1	Power supply (300W)	A6V10334250
FP2013-U1	S54400-Z61-A1	Power supply set (600W)	A6V10436206
FCA2015-U1	S54400-A63-A1	Dialer module (DACT)	A6V10334254
FCA2016-A1	S54400-A39-A1	RS485 class A module (iso.)	A6V10334252
FCA2018-U1	S54400-A65-A1	Remote peripheral module	A6V10315044
FTO2012-U1	500-692407	External parallel printer (PAL-1)	A6V10372650
FCA2033-A1	S54400-P154-A1	License key (S1)	A6V10350183
FCA2034-A1	S54400-P155-A1	License key (S2)	A6V10350183
FCA2035-A1	S54400-P156-A1	License key (S3)	A6V10350183
XCI2001-U1	S54400-A69-A1	Releasing module	A6V10315050
FN2001-U1	S54400-A60-A1	Network module (SAFEDLINK)	A6V10315042
FN2006-U1	S54400-A61-A1	Fiber network module (SM)	A6V10315048
FN2007-U1	S54400-A62-A1	Fiber network module (MM)	A6V10315048
FT2014-U3	S54400-B80-A1	Remote display (black)	A6V10315046
FT2014-R3	S54400-B73-A1	Remote display (red)	A6V10315046
FT2015-U3	S54400-B88-A1	Remote terminal (key, bl)	A6V10315046
FT2015-R3	S54400-B16-A1	Remote terminal (key, red)	A6V10315046
FCM2022-U3	S54400-C44-A2	Option module (blank)	A6V10315032
FCM2023-U3	S54400-C45-A2	Option module (LED)	A6V10315032
FHD2001-U3	S54400-B45-A1	Outer door (1HU, black)	A6V10335926
FHD2001-R3	S54400-B40-A1	Outer door (1HU, red)	A6V10335926
FHD2002-U3	S54400-B32-A1	Outer door (2HU, 1 win, bl)	A6V10335926
FHD2002-R3	S54400-C53-A1	Outer door (2HU, 1 win, red)	A6V10335926
FHD2003-U3	S54400-C42-A1	Outer door (2HU, 2 win, bl)	A6V10335926
FHD2003-R3	S54400-B46-A1	Outer door (2HU, 2 win, red)	A6V10335926
FHD2006-U1	S54400-C46-A1	Clear window	A6V10335926
FHB2001-U1	S54400-B47-A1	Back box (1HU, black)	A6V10335922
FHB2001-R1	S54400-B47-A2	Back box (1HU, red)	A6V10335922
FHB2002-U1	S54400-B48-A1	Back box (2HU, black)	A6V10335922
FHB2002-R1	S54400-B48-A2	Back box (2HU, red)	A6V10335922
FHD2004-U1	S54400-B52-A1	Inner door (black)	A6V10335929
FHD2005-U1	S54400-B53-A1	Inner door (solid, black)	A6V10335929
FHA2031-U1	S54400-B44-A1	DIN Rail Set	A6V10334278
FHA2032-U1	S54400-B43-A1	Battery bracket	A6V10334280
FHA2035-U1	S54400-B42-A1	Trim Kit 1HU Black	A6V10350024
FHA2035-R1	S54400-B44-A2	Trim Kit 1HU Red	A6V10350024
FHA2036-U1	S54400-B41-A1	Trim Kit 2HU Black	A6V10350024
FHA2036-R1	S54400-B42-A2	Trim Kit 2HU Red	A6V10350024
FT2003-U1	S54400-C136-A1	Graphic driver (I/O)	A6V10384377
FCA2032-U1	S54400-B145-A1	Battery disconnect module	A6V10385200
FHD2012-U1	S54400-C135-A1	Inner Door RDT (black)	A6V10385202
FCL2004-U1	S54400-A68-A1	MXL Device Interface Module	A6V11415283

Model Number	Part Number	Description	Product Insert Number
FCL-MXLPLATE	S54400-B153-A1	Adapter plate to mount the FCL2004 loop driver	A6V11877890
FCM2034-U3	S54400-C138-A1	Option module (LED r/y, y)	A6V10315032
FCM2035-U3	S54400-C140-A1	Operating unit (+ LED)	A6V10315030
FHA-MIQKIT-04	S54400-C24-A1	MXL-IQ Mechanical Migration Kit	A6V11420345
FHA-MIQKIT-05	S54400-C25-A1	MXL-IQ Mechanical Migration Kit	A6V11420345
FHA2056-U1	S54400-B18-A1	FS250/MPC Mech Migration Kit (Black)	A6V101004423
FHA2056-R1	S54400-B19-A1	FS250/MPC Mech Migration Kit (Red)	A6V101004423
Connect X300 Gateway	S55842-Z121-A100	CXG3.X300 Connect X300	A6V11649121

Table 6: Fire-Voice Installation Instruction Part Numbers

Model Number	Part Number	Description	Product Insert Number
VCA2002-A1	S54400-A47-A1	Card cage (4 amplifiers)	A6V10380472
VCC2002-A1	S54400-A41-A1	Voice I/O card	A6V10397774
VCC2001-A1	S54400-A40-A1	Voice CPU card	A6V10397772
VC12001-U1	S54400-A45-A1	Voice amplifier card (25V)	A6V10370410
VN2001-A1	S54400-A42-A1	Ethernet Module (electric)	A6V10370415
VN2002-A1	S54400-A43-A1	Ethernet Module (MM)	A6V10370419
VN2003-A1	S54400-A44-A1	Ethernet Module (SM)	A6V10370419
VC12003-A1	S54400-A141-A1	VoIP module	A6V10380474
VTA2001-A1	S54400-F163-A1	Remote terminal board (Class B)	A6V10405564
VTO2001-U3	S54400-C60-A1	Option module (24 switches)	A6V10370342
VTO2004-U3	S54400-C61-A1	Option module (Microphone)	A6V10370377
FHB2005-U1	S54400-B110-A1	Back box (3HU, black, deep)	A6V10359788
FHB2005-R1	S54400-B110-A2	Back box (3HU, red, deep)	A6V10359788
FHD2007-U3	S54400-B113-A1	Outer Door (3HU, 3 win, bl)	A6V10360714
FHD2007-R3	S54400-B113-A2	Outer Door (3HU, 3 win, red)	A6V10360714
FHA2041-R1	S54400-B93-A1	Enclosure cover	A6V10370383
FHA2042-U1	S54400-B55-A1	Battery bracket (33 Ah)	A6V10370385
FHA2043-U1	S54400-B56-A1	Trim kit (3HU, black)	A6V10370379
FHA2043-R1	S54400-B57-A1	Trim kit (3HU, red)	A6V10370379
FHD2009-U1	S54400-B114-A1	Blank plate (black)	A6V10359792
FHD2009-R1	S54400-B114-A2	Blank plate (red)	A6V10359792
FCA2031-A1	S54400-A153-A1	Connection module (MoNet)	A6V10407860
FN2012-A1	S54400-B152-A1	Ethernet switch (modular)	A6V10407862
FT2007-U1	S54400-A142-A1	LED annunciator driver	A6V10456395
FT2008-U1	S54400-A143-A1	Tabular annunciator (16 z, bl)	A6V10456397
FT2008-R1	S54400-A144-A1	Tabular annunciator (16 z, red)	A6V10456397
FT2009-U1	S54400-A145-A1	Tabular annunciator (32 z, bl)	A6V10456397
FT2009-R1	S54400-A146-A1	Tabular annunciator (32 z, red)	A6V10456397
PAD-5	S54339-A5-A1	Power Expander Main Board	A6V101030358
PAD-5-CLSA	S54339-A6-A1	Class A/B Expansion Board w/ Releasing	A6V101030359
PAD-5-CDC	S54339-A7-A1	Conventional Detector Expansion Board	A6V101030366

Table 7: Battery Calculation Form

Ref. No. _____

Submitted By: _____

Project Name: _____

Project Location: _____

Panel Location: _____

Node No: _____ Date: _____

	Enter value
	Select choice
	Fixed
	Calculated

Module	Description	Module Feature	Qty	Standby Current	Alarm Current	Comments
FCM2018-U3	Operating Unit			0.000	0.000	125 mA (standby), 166 mA (alarm) per module
FCM2019-U3	Operating Unit			0.000	0.000	130 mA (standby), 170 mA (alarm) per module
	(+ LED)	LED zones				1 mA per zone (3 LEDs per zone)
FCI2016-U1	Periphery board (250p)			0.000	0.000	110 mA (standby), 136 mA (alarm)
		SLC load				Calculated device load from below
		NAC load ²				NAC alarm current from signals
		Aux power load ¹				External Aux power for standby & alarm
		Bell Follower	No		0.000	0.000
FCI2017-U1	Periphery board (500p)			0.000	0.000	120 mA (standby), 136 mA (alarm)
		SLC load				Calculated device load from below
		NAC load ²				NAC alarm current from signals
		Aux power load ¹		0.000	0.000	External Aux power for standby & alarm
		Bell Follower	No		0.000	0.000
FCI2011-U1	NAC module (1A/2B)	No	0	0.000	0.000	15 mA (standby), 40 mA (alarm)
		NAC load ²				NAC alarm current from signals
XCI2001-U1	Releasing module	No	0	0.000	0.000	11 mA (standby), 40 mA (alarm) per module, 1 mA per releasing circuit
		Releasing load ²				Releasing alarm current from solenoids
FCI2020-U1	Leased line/city tie mod.	Not Installed		0.000	0.000	27 mA (standby), 40 mA (alarm) for LL; 2 mA (standby) 13 mA (alarm) for City Tie
FN2001-A1	Network module (SAFEDLINK)			0.000	0.000	35 mA per module
FCA2016-U1	RS485 class A module (iso.)			0.000	0.000	58 mA per module
FN2006-U1	Fiber network module (SM)			0.000	0.000	127 mA per module
FN2007-U1	Fiber network module (MM)			0.000	0.000	132 mA per module
FT2014-xx	Remote display (color)			0.000	0.000	34 mA (standby) 55 mA (alarm) per module
FT2015-xx	Remote terminal (key, color)			0.000	0.000	34 mA (standby) 55 mA (alarm) per module
FTI2001-U1	Fire Terminal Board			0.000	0.000	11 mA per module
FCM2023-U3	Option module (LED)			0.000	0.000	5 mA per module
		LED zones		0.000	0.000	1 mA per zone (3 LEDs per zone)
FCA2015-U1	Dialer module (DACT)			0.000	0.000	25 mA (standby), 33 mA (alarm) per module
FCA2018-U1	Remote peripheral module			0.000	0.000	73 mA per module
FT2003-U1	Graphic driver (I/O)			0.000	0.000	19.5 mA (standby) 32 mA (alarm) per module
FCA2032-U1	Battery disconnect module			0.000	0.000	7 mA (standby) 12.6 mA (alarm) per module
VCA2002-A1	Card Cage			0.000	0.000	4 mA (standby) 4 mA (alarm)
VCC2002-A1	Voice I/O module			0.000	0.000	151 mA (standby) 156 mA (alarm) per module
VCC2001-A1	Voice CPU card			0.000	0.000	200 mA (stanby) 210mA(alarm) per module
VCI2001-U1	Voice ampl. Card (25V/70V)			0.000	0.000	196 mA(standby) 2.42A @ 25V (alarm) per module
VN2001-A1	Ethernet module (electric)			0.000	0.000	7 mA(standby) 7mA (active) per module

VN2002-A1	Ethernet module (MM)			0.000	0.000	35 mA(standby) 36mA(active) per module
VN2003-A1	Ethernet module (SM)			0.000	0.000	35mA(standby) 36 mA(active) per module
VCI2003-A1	VoIP module			0.000	0.000	43 mA (standby), 43 mA (alarm) per module
VTO2001-U2/-U3	Option module (24 Switches)			0.000	0.000	16mA (standby) 143mA (active)
VTO2004-U2/-U3	Option module (Microphone)			0.000	0.000	29mA (standby) 54 mA (active)
FCA2031-A1	Connection module (MoNet)			0.000	0.000	1 mA (standby), 1 mA (alarm) per module
FN2012-A1	Ethernet switch (modular)			0.000	0.000	340 mA (standby), 340 mA (alarm) per module
FT2007-U1	LED annunciator driver			0.000	0.000	25 mA (standby), 250 mA (max)
FT2008-U1/-R1	Tabular annunciator (16 z, color)			0.000	0.000	25 mA (standby), 65 mA (max)
FT2009-U1/-R1	Tabular annunciator (32 z, color)			0.000	0.000	25 mA (standby), 105 mA (max)
FCL2004-U1	MXL Device Interface Module			0.000	0.000	130mA + 1.5mA per device
Connect X300 Gateway	CXG3-X300 Connect X300			0.000	0.000	259 mA per module

Devices	Description	Qty	Stdby/Alm	Current Draw
HFP-11	Photo-thermal detector		0.00000	1.4 mA per device
HFPO-11	Photo detector		0.00000	1.4 mA per device
HFPT-11	Thermal detector		0.00000	1.4 mA per device
OOHC941	Dual optical/thermal/CO detector		0.00000	0.75 mA per device
OOH941	Dual optical/thermal detector		0.00000	0.68 mA per device
OH921	Photo-thermal detector		0.00000	0.28 mA per device
OP921	Photo detector		0.00000	0.28 mA per device
HI921	Thermal detector		0.00000	0.28 mA per device
FDCIO422	4-input/4-output module		0.00000	1.0 mA per device
HMS / 8700-S-D-M	Manual station		0.00000	1.4 mA per device
HTRI-S / 8702	Single input module		0.00000	1.4 mA per device
HTRI-D / 8703	Dual input module		0.00000	1.4 mA per device
HTRI-R / 8704	Single input/single relay Mod		0.00000	1.4 mA per device
XTRI-S	Addressable Switch Interface Mod w/ Dual Isolators (single input)		0.00000	0.65 mA per device
XTRI-D	Addressable Switch Interface Mod w/ Dual Isolators (Dual input)		0.00000	0.95 mA per device
XTRI-R	Addressable Switch Interface Mod w Dual Isolators (w/ relay)		0.00000	0.75 mA per device
XTRI-M	Addressable Switch Interface Mod w/ Dual Isolators (compact size)		0.00000	0.65 mA per device
XMS-D	Double action pull station		0.00000	0.50 mA per device
XMS-M	Single action pull station		0.00000	0.50 mA per device
XMS-S	Single action pull station		0.00000	0.50 mA per device
ILED-XW	Intelligent Remote Lamp – Wall mount (rectangular plate)		0.00000	0.50 mA per device
ILED-XC	Intelligent Remote Lamp – Ceiling mount (round plate)		0.00000	0.50 mA per device
TSM-1X	Intelligent Test Switch Module with Isolators		0.00000	0.50 mA per device
HZM / 8705	Conventional zone module		0.00000	1.4 mA per device
HCP / 8706	Addressable control point		0.00000	1.4 mA per device
HLIM	Loop Isolator Module		0.00000	1.0 mA per device
ILED /8726	Intelligent LED		0.00000	1.4 mA per device
PAD-5	Power Expander Main Board		0.00000	0.75 mA per expander
PAD-5-CDC	Conventional Detector Expansion Board		0.00000	0.75 mA per board

PAD-5-CLSA	Class A/B Expansion Board w/ Releasing		0.00000	1.25 mA per board	
Total		0	0.000	(included above)	System OK
Total Current			0.000	0.000	Use 170W power supply
Standby Time (hrs)		24	0.00		
Alarm Time (min)		30*		0.00	
AH required (no reserve)				0.00	
Battery Reserve		125%			
AH Required (with reserve)				0.00	System OK

Note 1: Ensure that the standby Aux power is not entered twice when used as external power source for optional modules.

Note 2: Max Alarm NAC Current = 3A/Circuit, Max Releasing Circuit Current = 2A/Circuit

Note 3: *Alarm time requirements offer multiple selections. Choose the appropriate time based on the requirements of your application. Options include: 5 minutes, 10 minutes, 15 minutes, 30 minutes, 60 minutes, and 120 minutes.

Battery Calculation

Battery backup is required for compliance to UL864 and ULC-S527. Refer to NFPA 72 and CAN/ULC-S524 for required standby time. To determine the battery, use Table 7 above and fill-out the required parameters.

- Record quantities of all required modules and devices per panel.
- Device Load Calculation: Place the # of devices in the yellow column, multiply with the current draw and place results in *Standby/Alarm* column. Add all results in the *Standby/Alarm* column to determine the total device current draw and place the result in the appropriate *SLC load* cell.
- Module Load Calculation: Place the # of modules and associated functions (e.g., LED zones, Bell Follower, etc) in the yellow column and multiply with associated current draw and place results in the appropriate column (Standby or Alarm).
- Place the NAC load and Releasing load during alarm in the *Alarm* Column.
- Add all results in the Standby Column to determine the *System Standby* Current.
- Add all results in the Alarm Column to determine the *System Alarm* Current.
- Place the required parameters: Standby Time (hr), Required Alarm Time (hr), Minimum Battery Size (Ahr), Minimum Battery Reserve (%)
- Calculate Battery Requirement for System Standby (Ahr) = System Standby Current (A) x Standby Time (hr)
- Calculate Battery Requirement for System Alarm (Ahr) = System Alarm Current (A) x Alarm Time (hr)
- Calculate the Battery Reserve (AH) = (Battery Reserve (%) / 100%) x (System Alarm Req + System Standby Req)
- Calculate the minimum battery Requirement = Battery Reserve + System Alarm Req + System Standby Req.

Select the battery that meets or exceeds the final calculated amp hour rating.

This page has been left intentionally blank.

Issued by
Siemens Industry, Inc.
Smart Infrastructure
8 Fernwood Road
Florham Park, NJ 07932
Tel. +1 973-593-2600
www.downloads.siemens.com/dlc

© 2020 Siemens Industry, Inc.
Technical specifications and availability subject to change without notice.